

Activation of a Temporal, Spectral, and Spatially-Shaped Front End for Generation of Inertial Fusion Energy Drive Pulses on the Mercury Laser

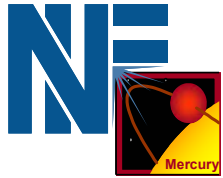

A.J. Bayramian, J. P. Armstrong, R.J. Beach,
C. Bibeau, C.A. Ebbers, B.L. Freitas, B. Kent,
T. Ladran, S.A. Payne, and K.I. Schaffers

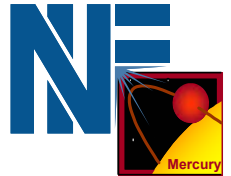

The front end design utilizes fiber technology and established Mercury technologies to provide a stable robust system

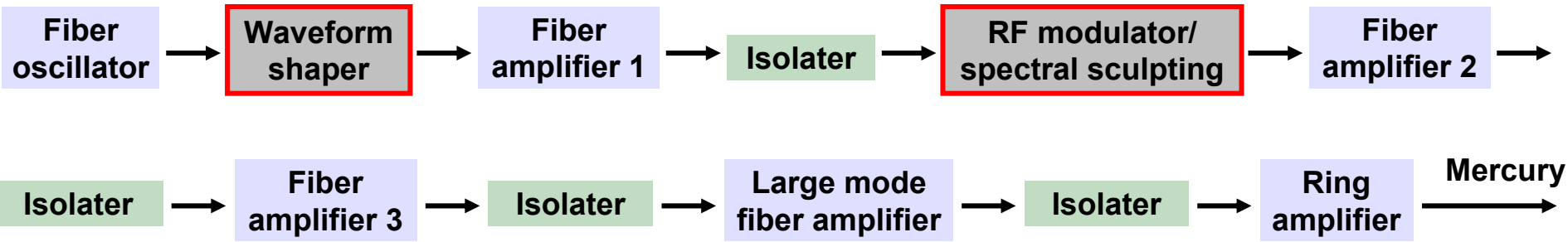
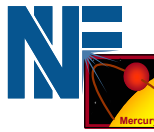

Primary mission requirements:

1. Spectral bandwidth - beam smoothing by spectral dispersion (dithering of speckle pattern on target surface decreases imprinting and Rayleigh Taylor instabilities)
2. Temporal pulse shaping – necessary to avoid preheating target, compressing along proper adiabat, and optimizing fusion gain

Laser specifications:

- 10 Hz pulse repetition frequency
- 500 mJ output energy
- 3 GHz spectral stability
- < 5% temporal amplitude fluctuations
- < 250 ps temporal jitter
- 20:1 temporal contrast to limit square pulse distortion
- 150 GHz spectral bandwidth (300 GHz possible)
- 100:1 spectral contrast
- 10,000:1 contrast ratio between main 1047 nm signal and noise
- Beam quality: $M^2 < 1.1$

The front end laser system is being commissioned

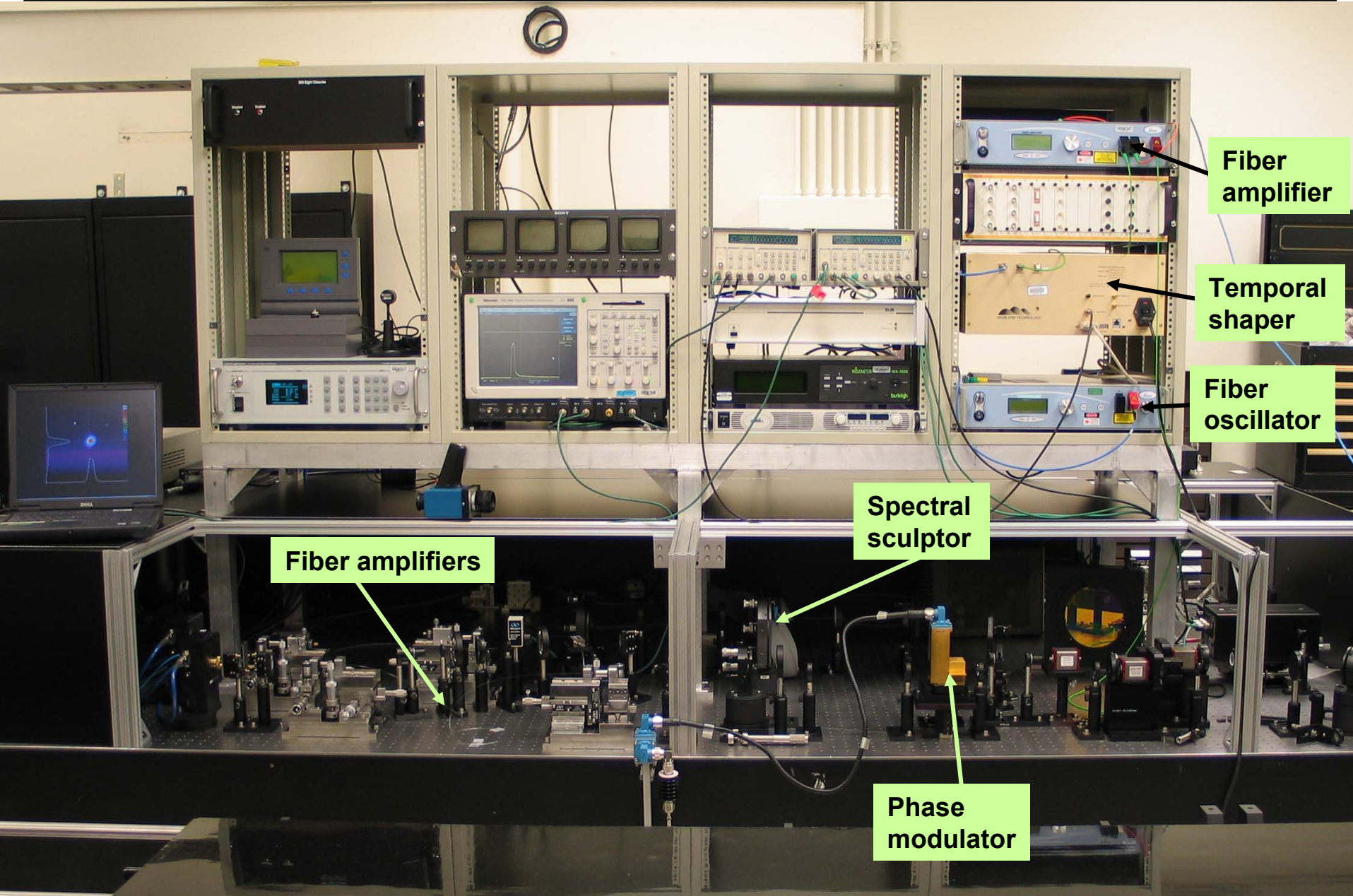

Fiber amplifier

Temporal shaper

Fiber oscillator

Spectral sculptor

Fiber amplifiers

Phase modulator

Procurement and Commissioning status

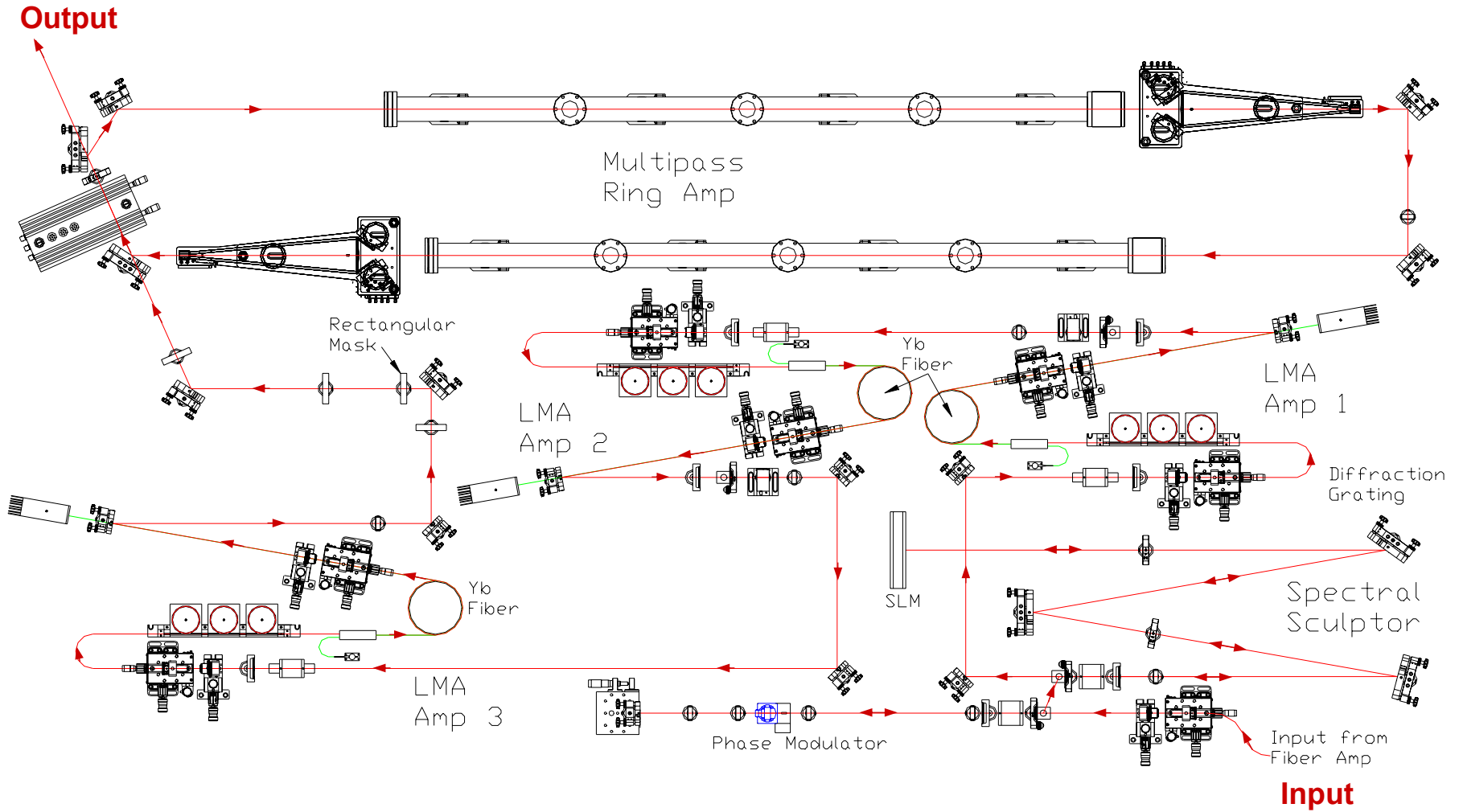
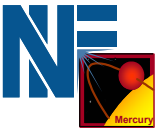

Commissioned

Buildup, alignment & testing

Parts ordered

We have chosen a Keopsys distributed feedback oscillator as the source for the front end

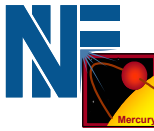

Specifications:

- 1047.7 nm center wavelength with 1nm tuning
- Single longitudinal mode with <math><100\text{kHz}</math> linewidth
- Power output > 10mW
- Linearly polarized output with greater than 50:1 extinction
- Polarization controller on output
- Computer controllable

Keopsys Inc. fiber oscillator

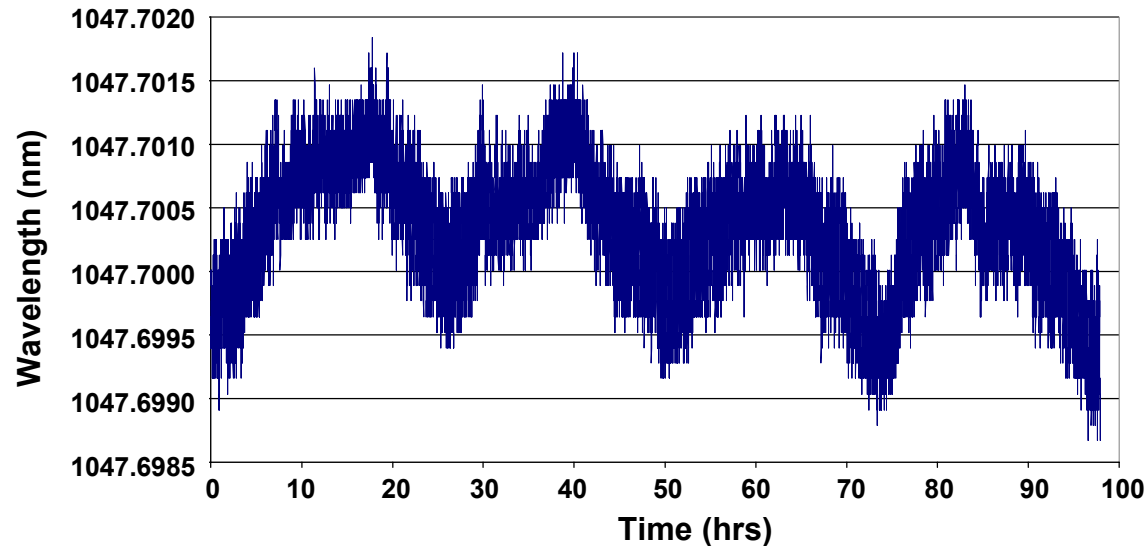
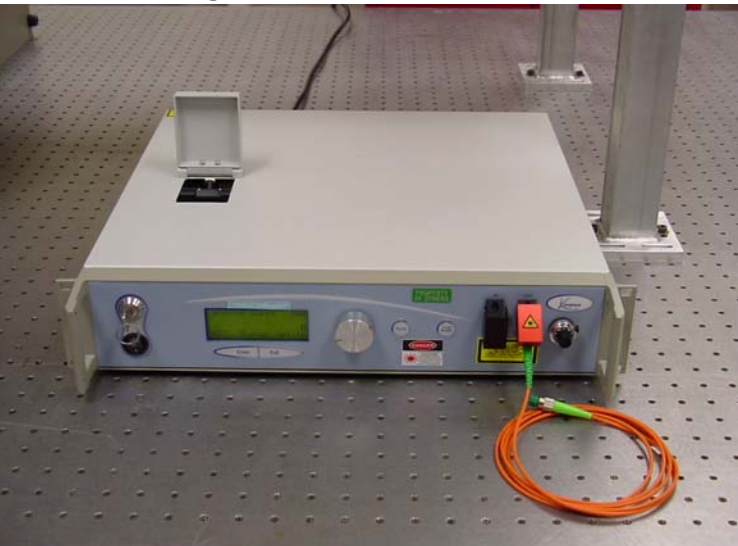

Wavelength drift is <math><300\text{ MHz}</math> which meets 3 GHz stability requirement

A Highland Technology arbitrary waveform generator provides temporal waveform control

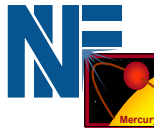

Specifications:

- Dual-stage electro-optic modulator
- 27 dB single-stage on/off extinction
- 6 dB insertion loss
- 96 temporal adjustment points across 24 nsec yielding 250 psec resolution
- Computer controllable

Highland Technologies temporal shaper (NIF design)

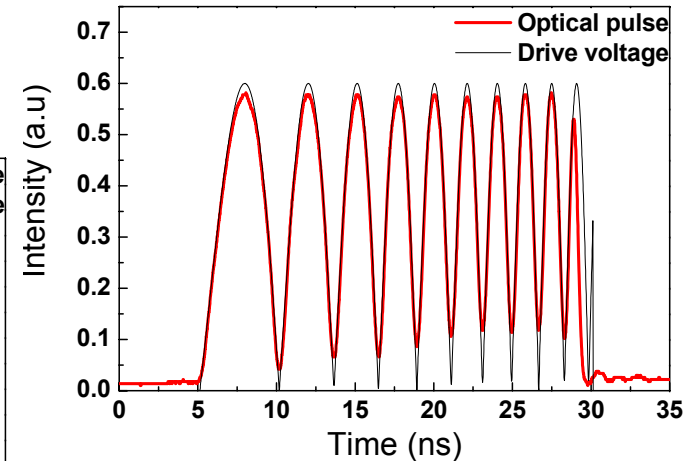
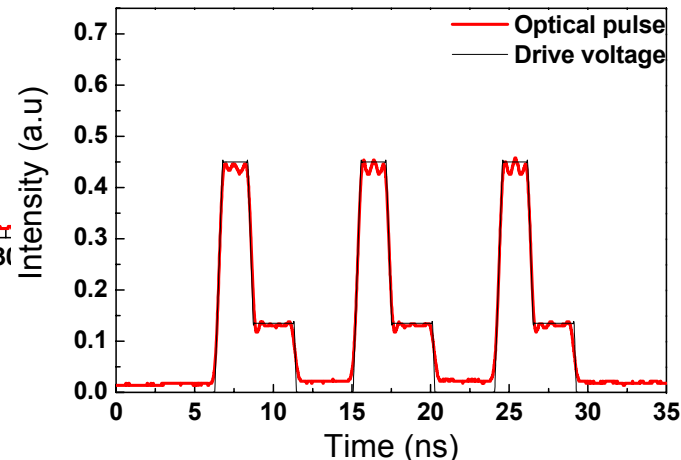
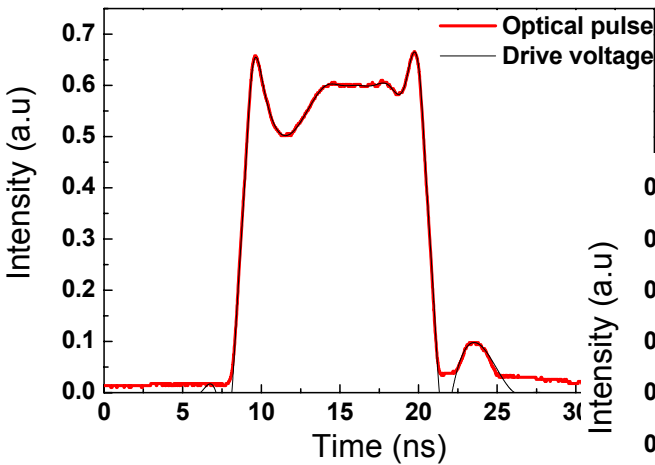

Fiber amplifier has suitable gain for the front end system

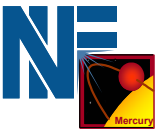

Specifications:

- Yb-doped fiber amplifier
- Polarization maintaining amplifier
- 30 dB small-signal gain
- Computer controllable

Keopsys Inc. fiber amplifier



Fiber amplification demonstration

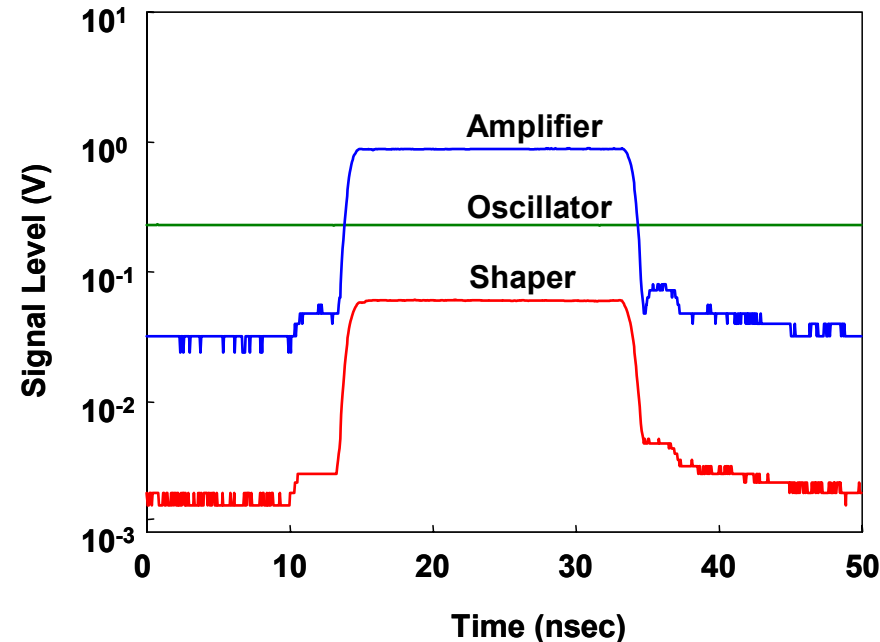

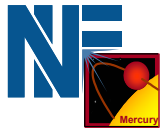

- Specifications:**
- Bulk LiNbO₃ modulator with 5 x 5 mm aperture
 - Capable of RF modulation up to 300 GHz (double pass)
 - Low optical loss (< 1%)

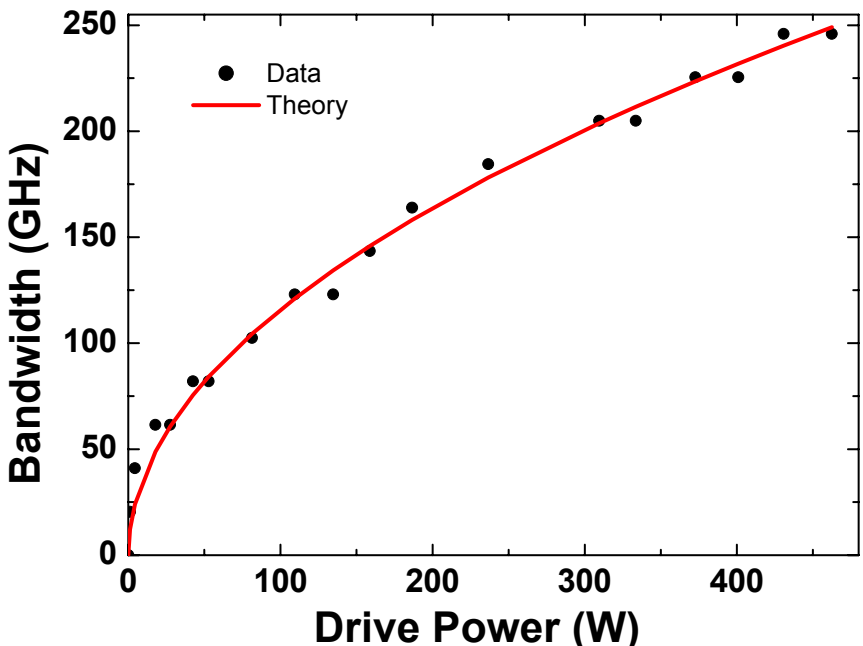
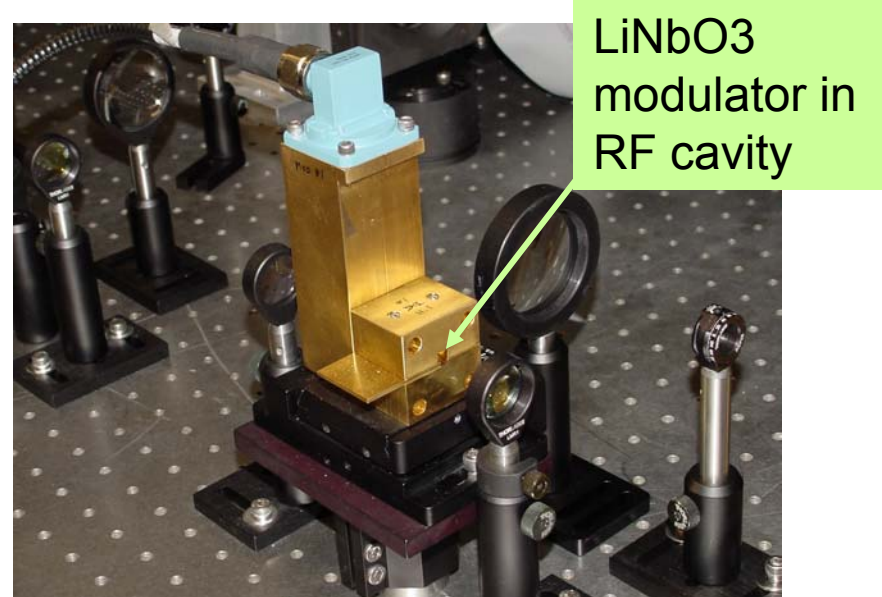

Demonstration of 250 GHz RF

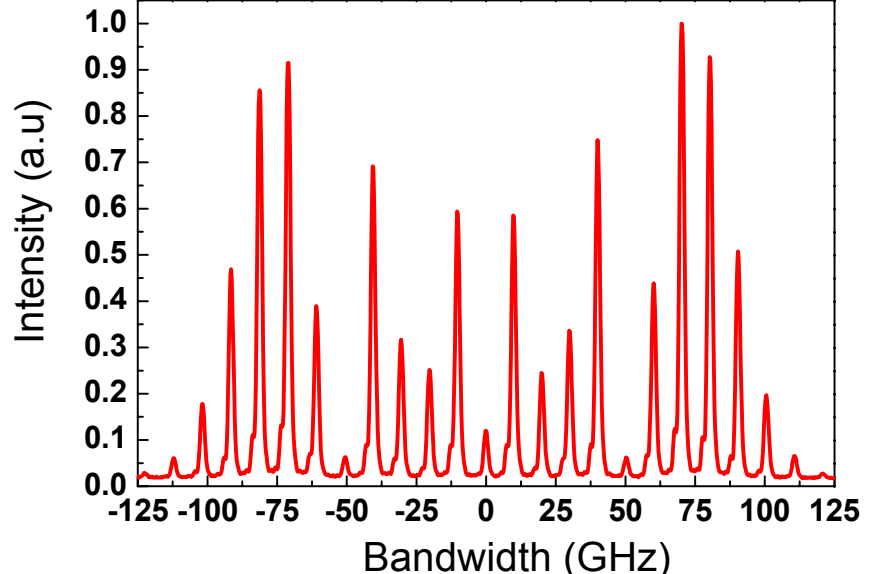

Spectral sculpting is required to reduce the effects of gain narrowing (FM to AM modulation)

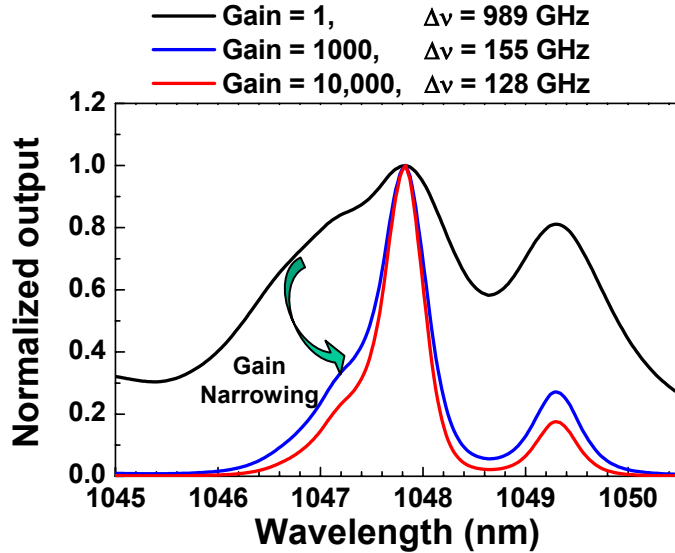
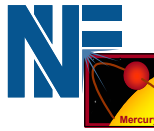

The single frequency input to the phase modulator is converted to a sinusoidally varying frequency with time

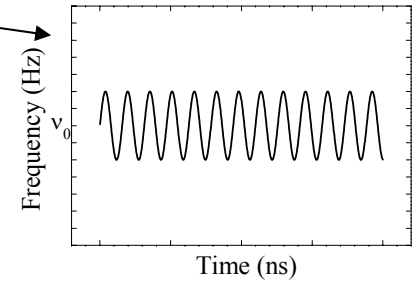

Input to amplifier

Output of amplifier

No Sculpting

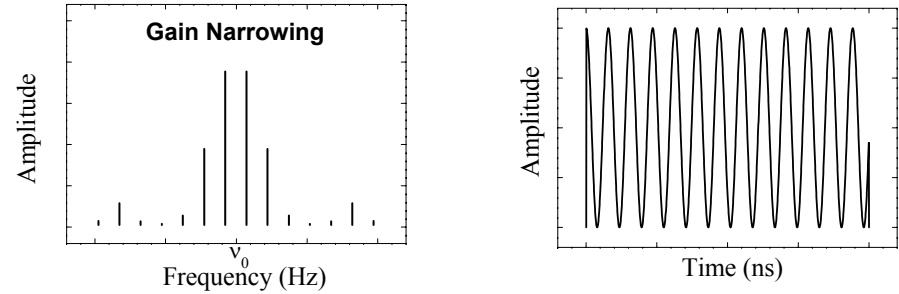
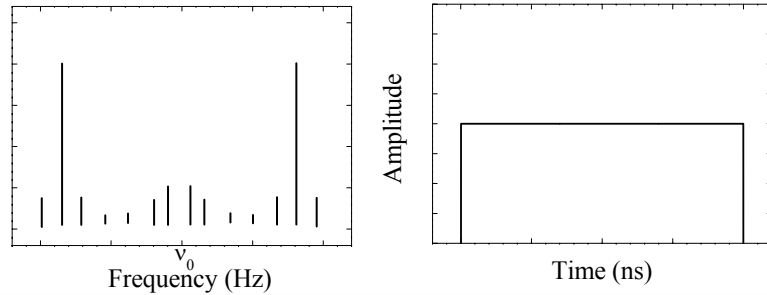

Sculpted

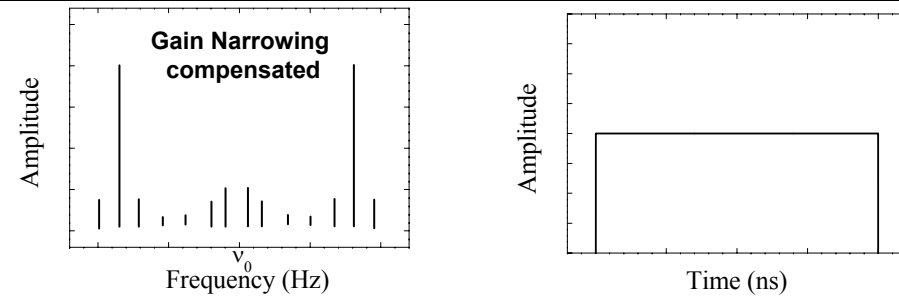
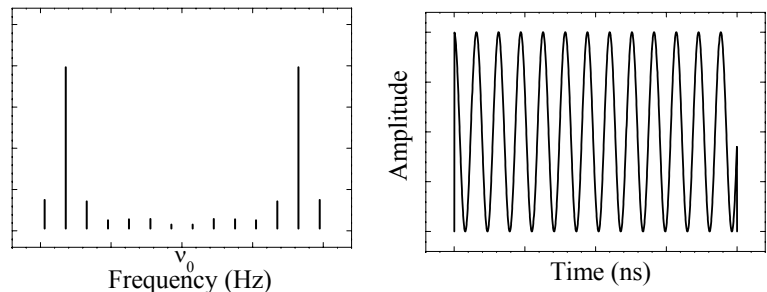

The front end upgrade will provide temporal and spectrally sculpted broadband pulses

Phase modulator

Diffraction grating

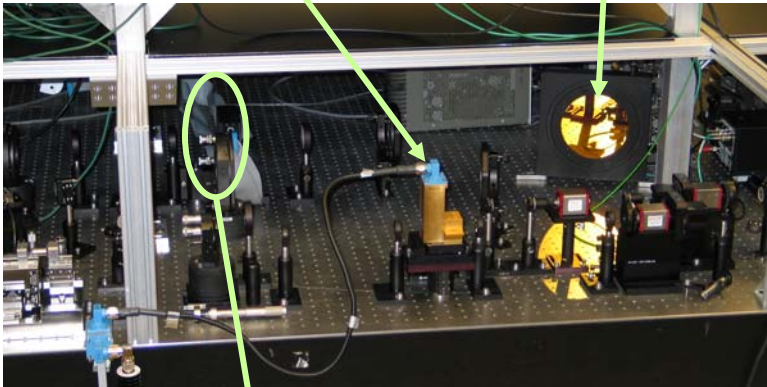

Liquid Crystal Modulator (LCM)

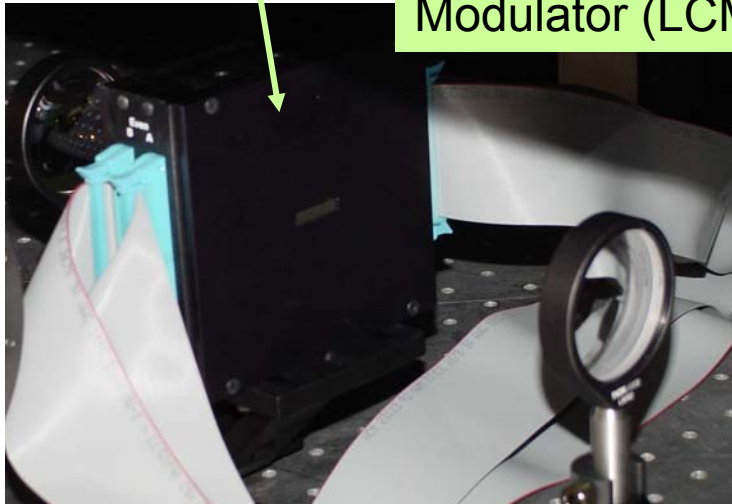

Specifications:

- 100:1 spectral contrast
- 100 x 3000 μm pixels
- Independent control of amplitude and phase

Sculpting demonstration with a Gaussian amplitude mask

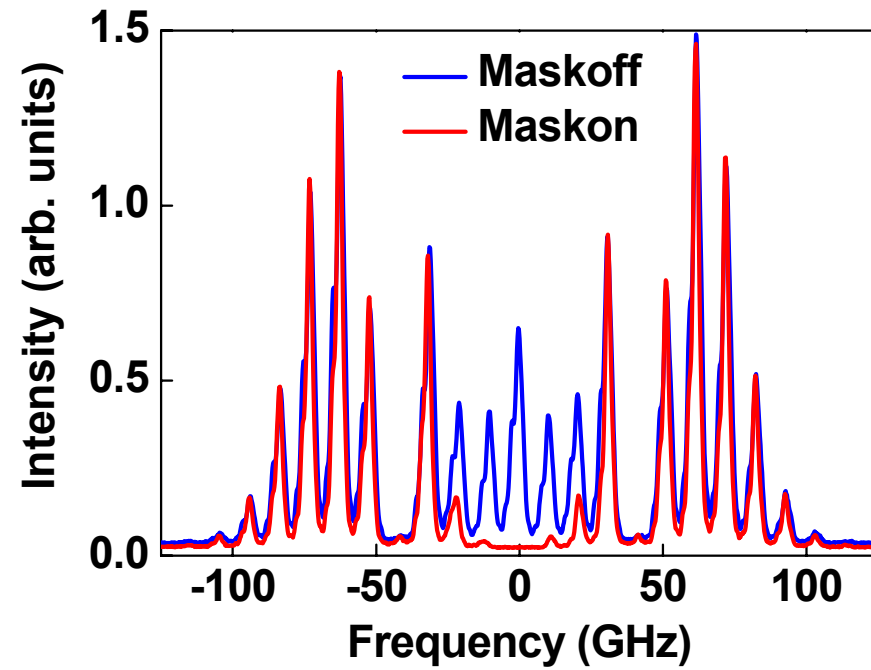

Detailed design of the Large Mode Area (LMA) fiber amplifiers

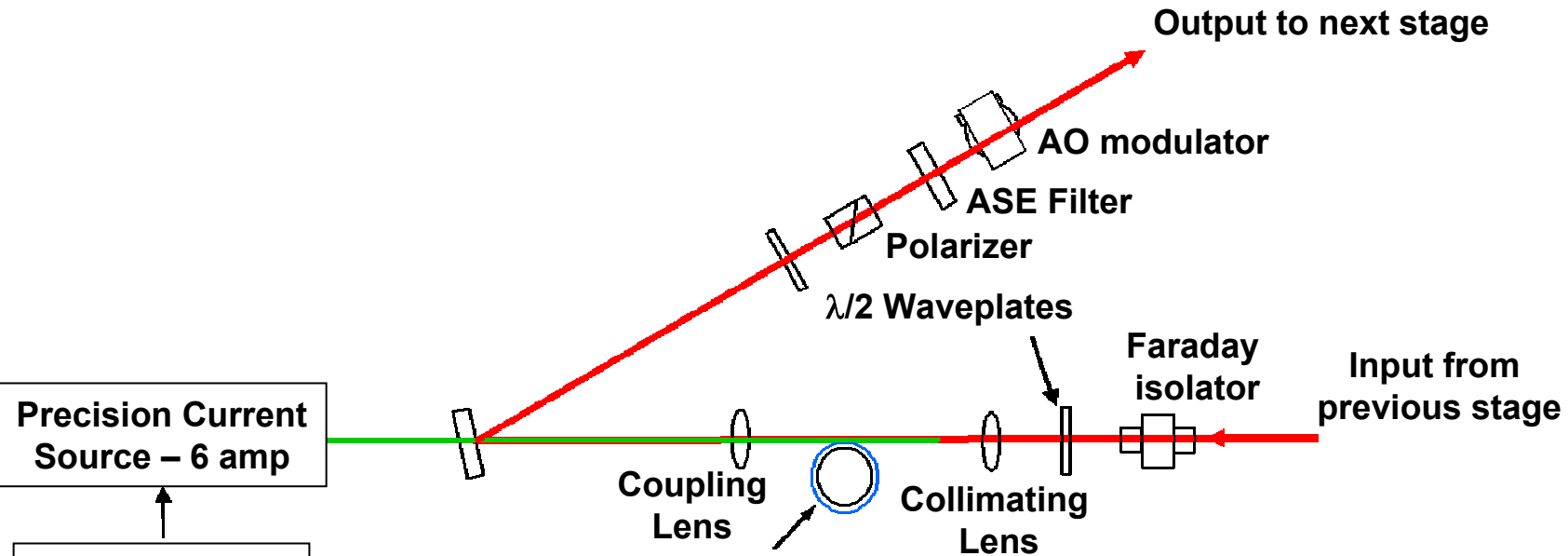
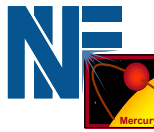

15 or 30 μm core Yb fiber, dependent upon desired output energy

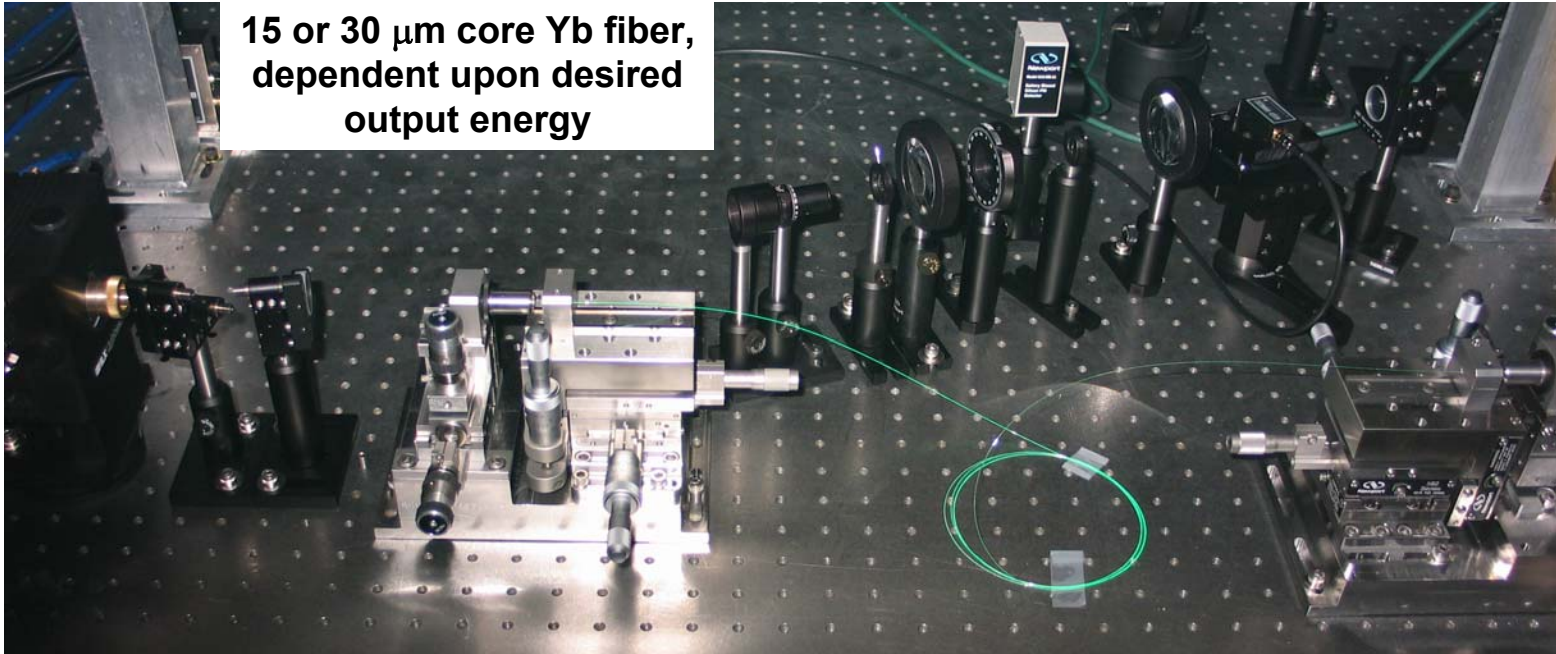

Testing has begun on the first of the Large Mode Area (LMA) fiber amplifiers

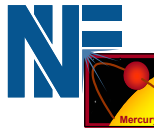

Diode P-I curve

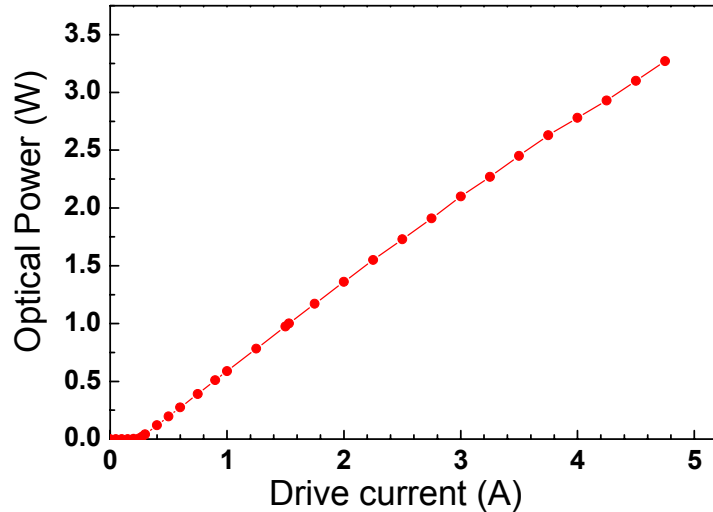

Output mode quality

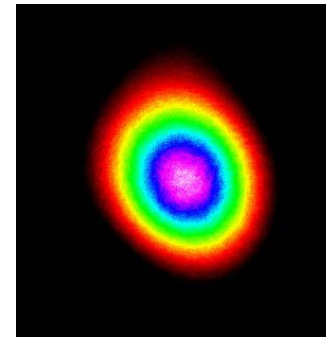

Temporal profiles

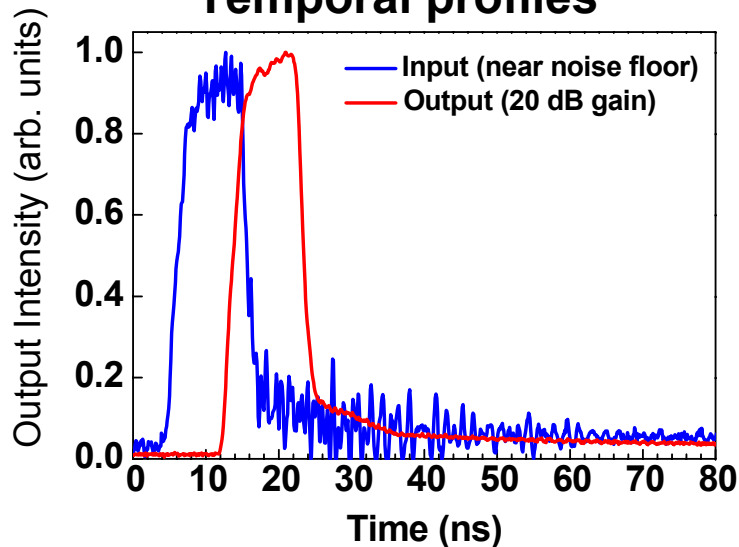

Fiber gain curve

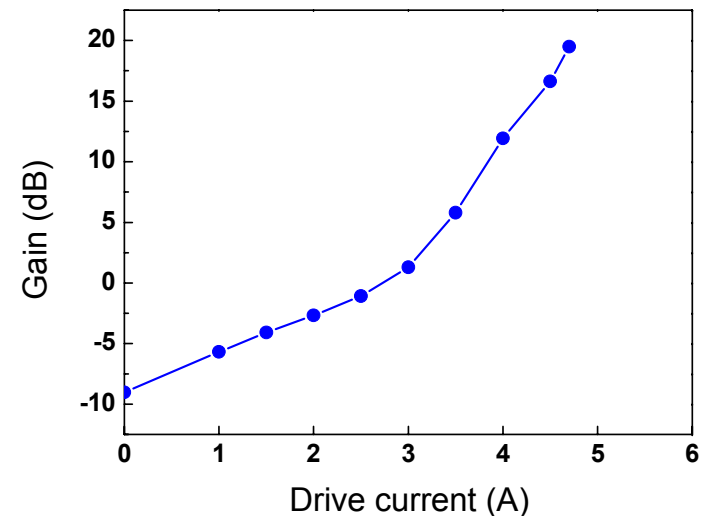

Specifications:

- **Output energy = 500 mJ**
- **Repetition rate = 10 Hz**
- **Beam spatial profile = Supergaussian w/ 1.67:1 aspect ratio**
- **Polarization: Linear, S-polarized 100:1**
- **Supported pulsewidths: 2-10 ns**
- **Supported bandwidths: ≥ 300 GHz RF**
- **Output pulse maintains 20:1 temporal shaping for Mercury**

Layout for multipass ring amplifier

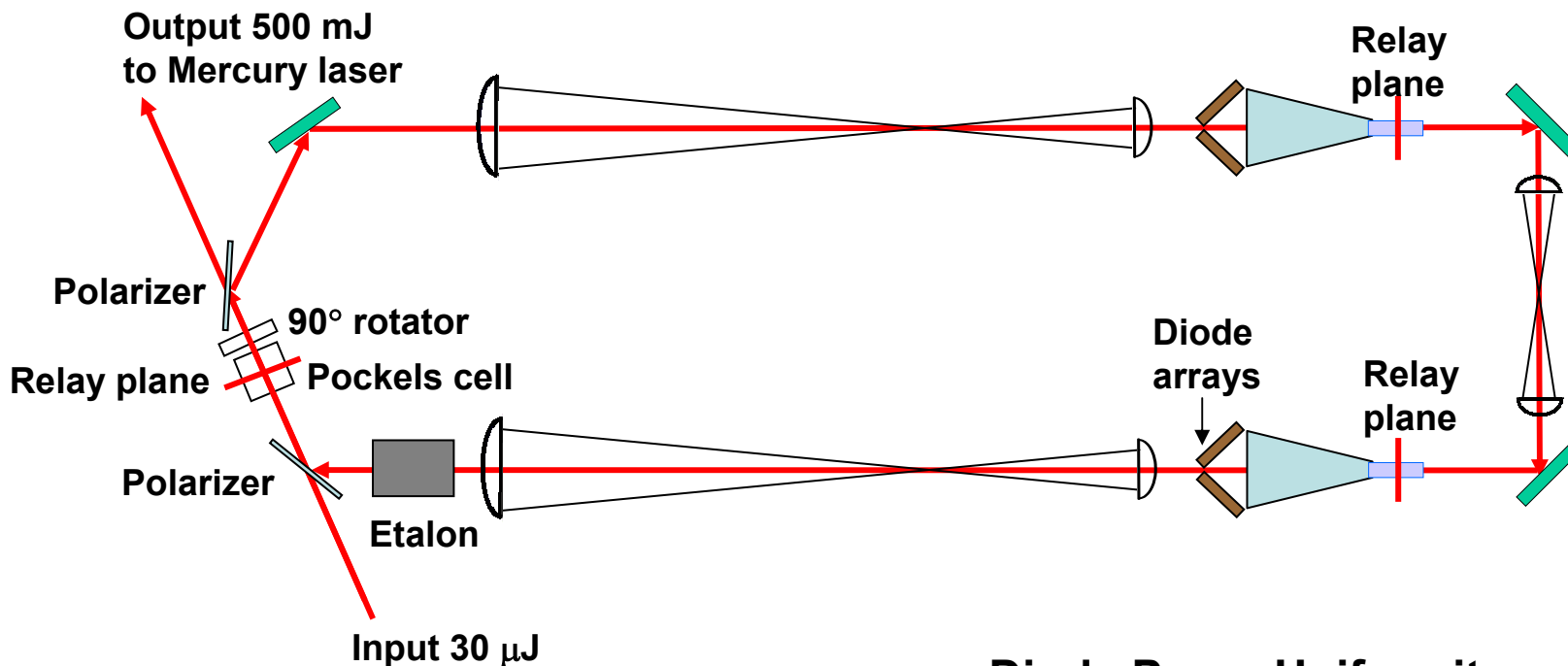
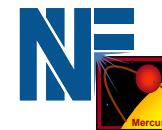

Features:

- 7.85 meter cavity gives 26.2 ns round trip time
- Second polarizer prevents extra roundtrip in the wrong polarization
- Inject P, Pockels off – Pockels on, circulate S, Pockels off, eject P

Diode Pump Uniformity

Duct output

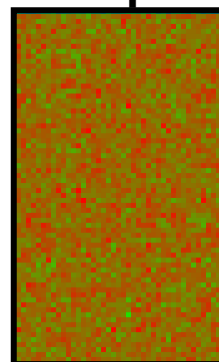

Crystal exit

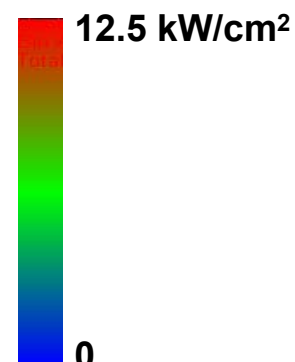
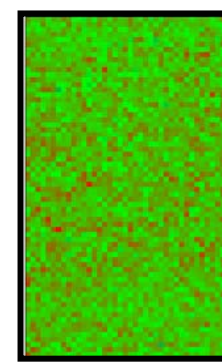

Modeling indicates the S-FAP multi-pass power amplifier will meet requirements

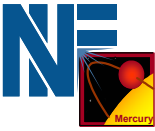

Energetics Parameters:

- 2 S-FAP crystals
- 7x4.2x20 mm duct output
- 1.46 J extractable stored energy
- 2% of thermal fracture
- Gain = 5.5 (round trip)
- Number of roundtrips = 8
- Average Fluence $\sim 3 \text{ J/cm}^2$ ($= F_{\text{sat}}$)
- Input: 30 μJ , Output: > 500 mJ

The temporal pulse shows the effects of both temporal and spectral sculpting

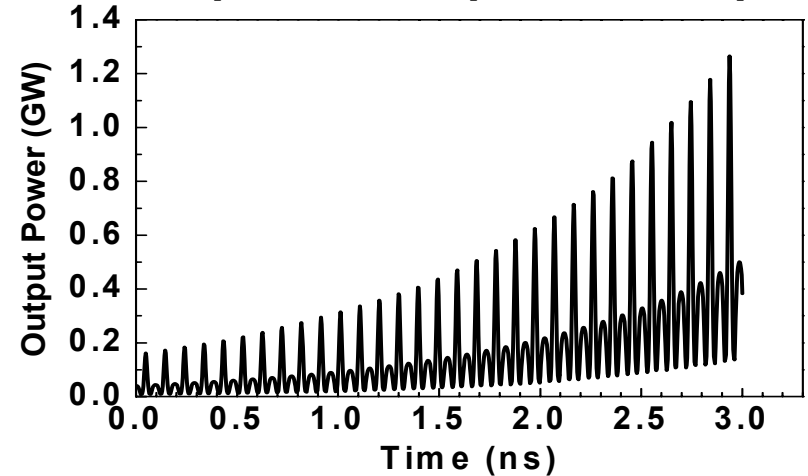

Front end output energy and B-integral versus Front end input

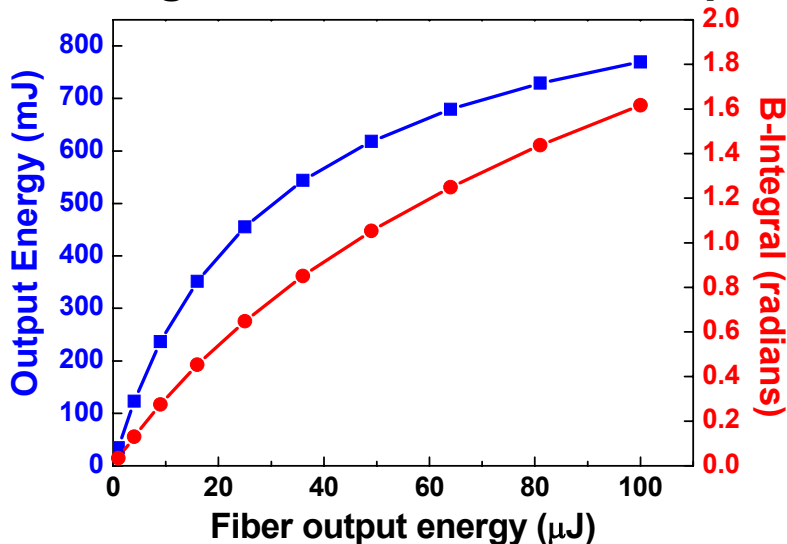

Intracavity etalon
uses undoped YAG for gain flattening
276 μm thick with uncoated surfaces

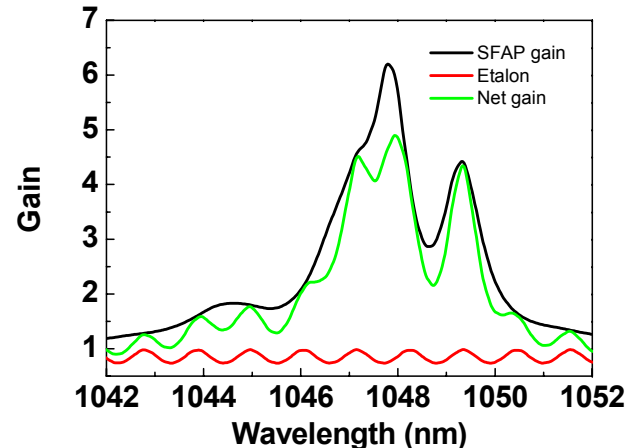

A MIRO model has been written to understand 3-D energetics, effects of phase and diffraction from apertures in the ring

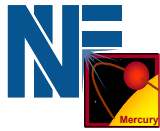

- Injection profile = 10th order Super-gaussian
- Output shown using 3 mm (2 mrad) pinholes
- Hard aperture at amplifier location = 4.2 x 7 mm

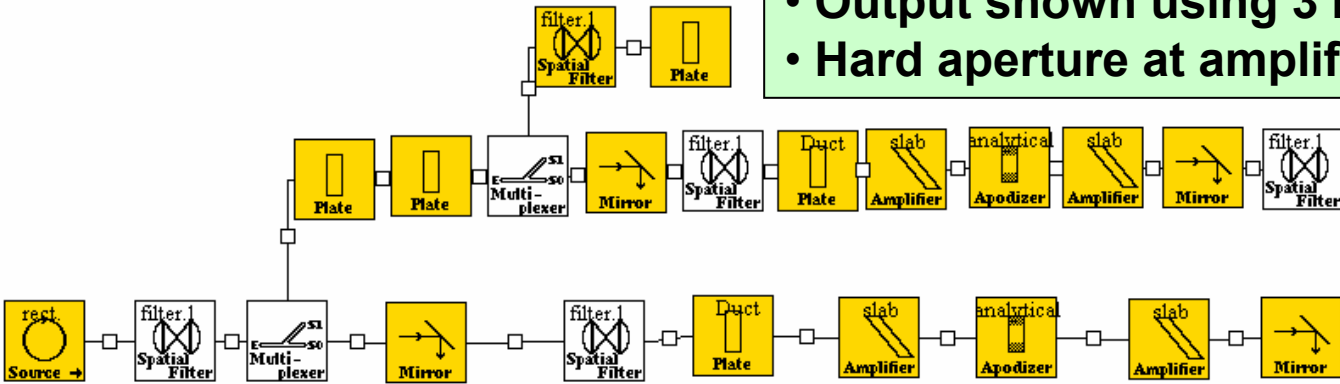

Output 3-D intensity profile

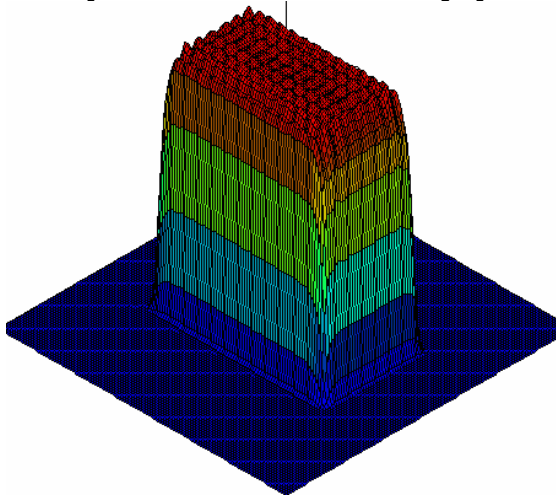

Lineouts of output profile

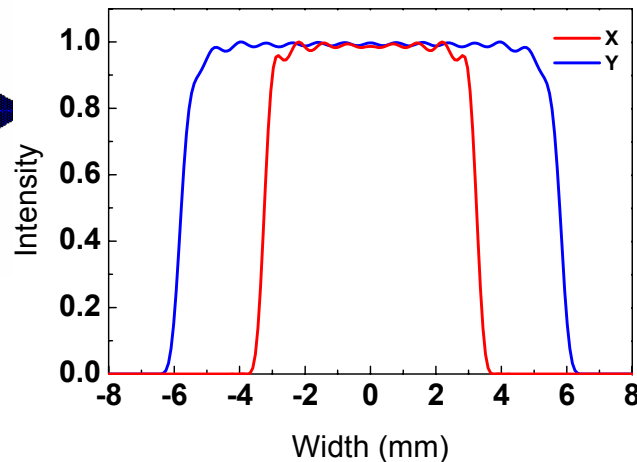

Histogram of fluences through ring amplifier

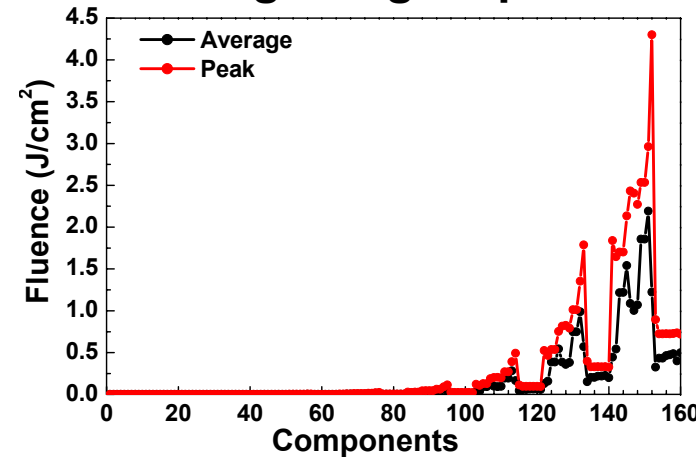

The Yb:S-FAP ring amplifier utilizes the same pumping architecture as Mercury

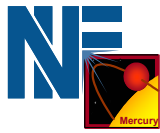

Amplifier enclosure for laser safety and nitrogen purge

2.3kW diode arrays
Mounted on copper cooling blocks

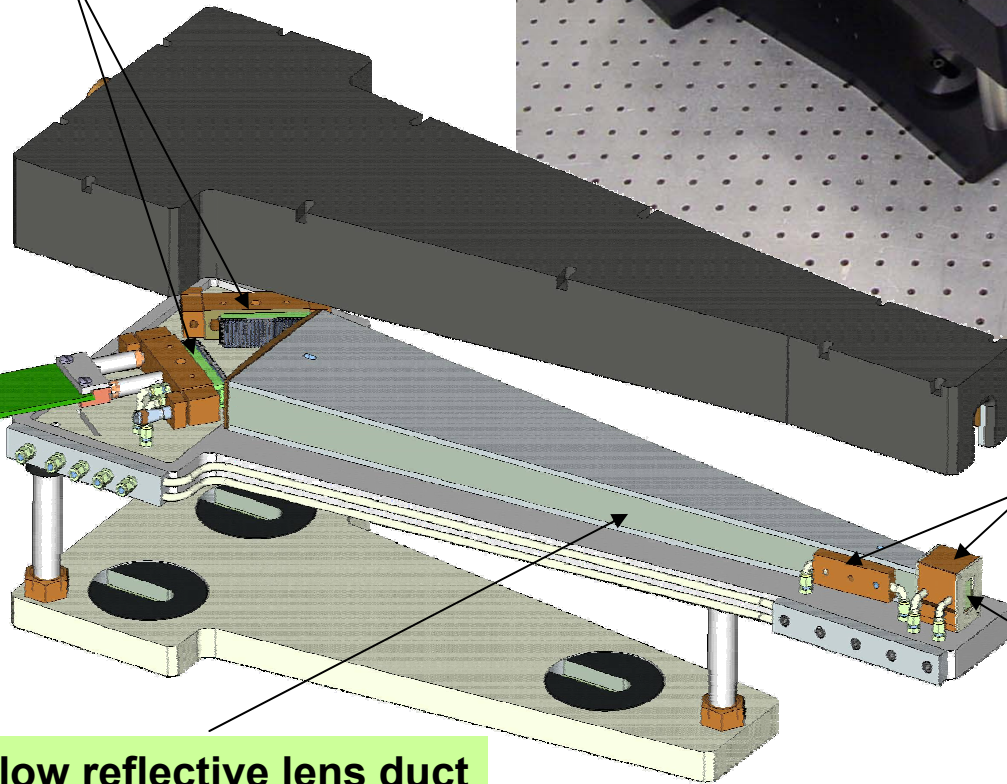
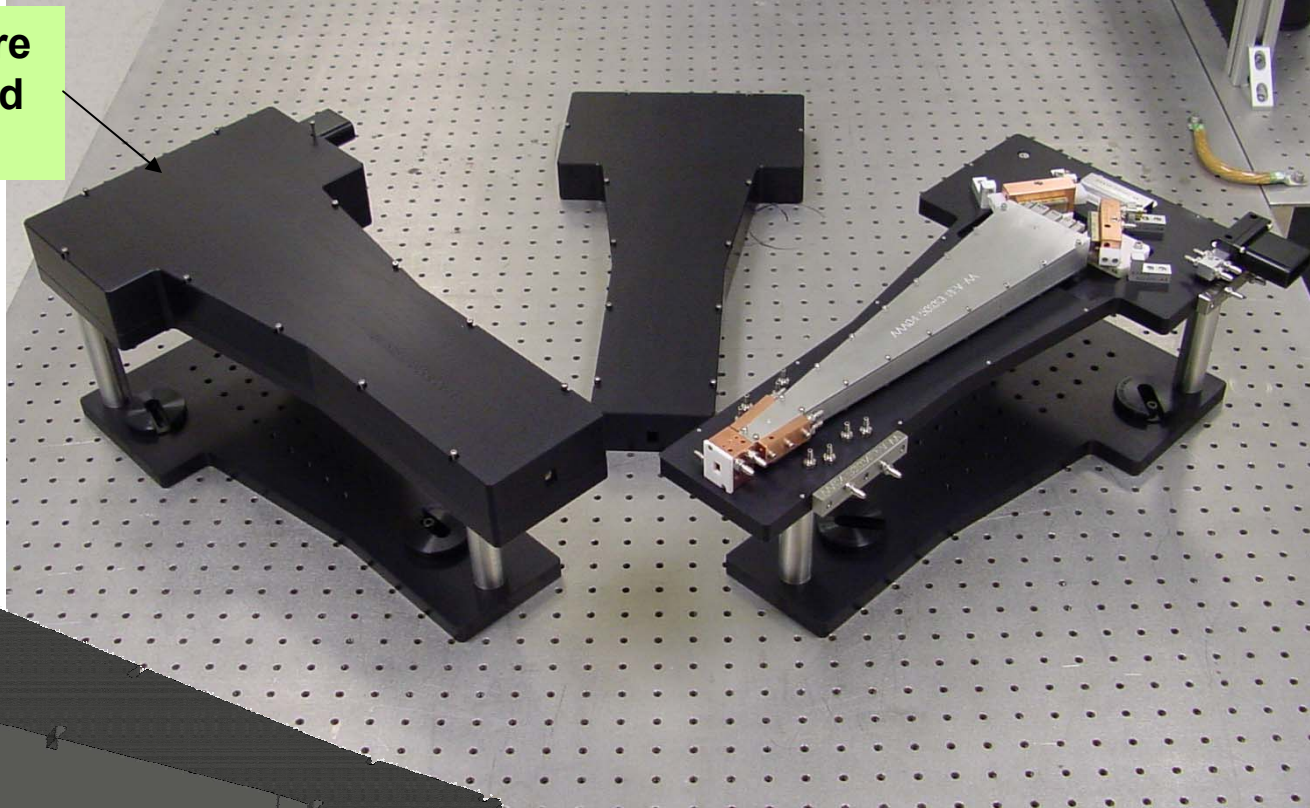

Copper block cooling manifold for crystal and duct

6 x 9 x 20 mm S-FAP amplifier

Hollow reflective lens duct